

TEST PRESSURE Kg/Sq.Cms	Hydraulic-No Test	Design Reference	ASME/ANSI-B16.5-1988 Ed
	Pneumatic-Notest	Testing Reference	Not Applicable
FLANGES	Ref-PEC/Customer	NDT -On Request	Not-Applicable

AVAILABLE-OPTIONS

OPERATION- Pneumatic/Gear/Hydraulic/Chain/Motorized
SHAPE- Round/Rectangular/Round-Square
SEAT- PTFE/EPDM/Silicon/Require

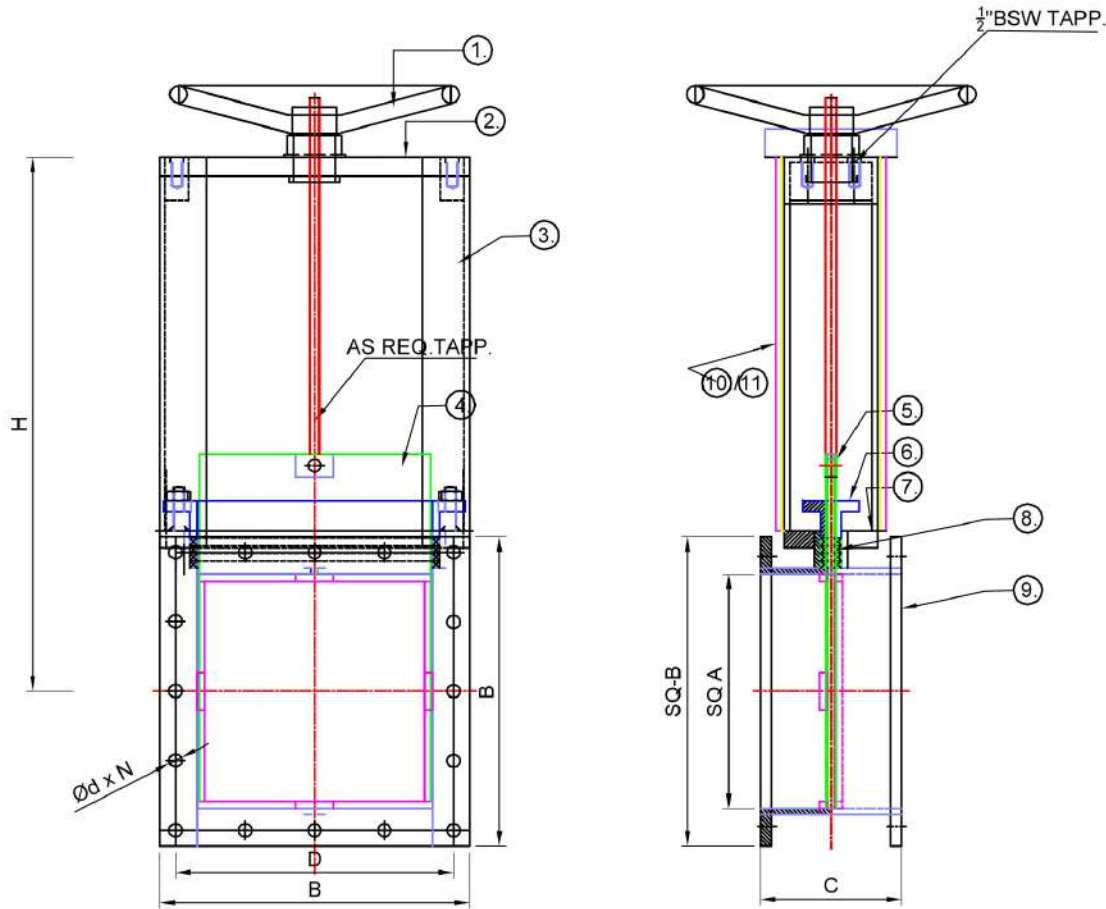

DIMENSION-TABLE

ALL DIMENSIONS IN MM & FOR REFERENCE ONLY

700 x 700	700	800	200	1200	21	20	
600 x 600	600	700	200	1050	18	20	
500 x 500	500	612	175	900	18	20	
400 x 400	400	500	175	750	18	12	
350 x 350	350	438	175	650	14	12	
300 x 300	300	388	150	600	14	12	
250 x 250	250	325	150	525	14	12	
200 x 200	200	275	150	450	14	12	
150 x 150	150	220	150	375	14	8	
125 x 125	125	185	150	350	14	8	
100 x 100	100	160	150	300	10	8	
Size mm	A	B	C	H	Ød	N	

11.	FRAME COVER GASKETS	RUBBER/STANDARD	6	
10.	FRAME COVERS	M.S./MALLEABLE/REQUIRE	2	
9.	BODY FLANGE	M.S./MALLEABLE/REQUIRE	2	
8.	GLAND PACKING	ASBESTOS	4	
7.	GLAND HOUSING	M.S./MALLEABLE/REQUIRE	1	
6.	GLAND BUSH	M.S./MALLEABLE/REQUIRE	1	
5.	GATE MOUNTING-PLATES	M.S.	2	
4.	GATE	M.S./AISI-304/316/REQUIRE	1	
3.	VERTICAL CHANNEL	M.S.	2	
2.	YOKE PLATE	M.S./MALLEABLE/REQUIRE	1	
1.	HAND-WHEEL	M.S./MALLEABLE/REQUIRE	1	
NO.	NAME	MATERIAL	Qty.Nos.	REMARKS

BILL OF MATERIAL

4.						 PROCESS EQUIPMENT CORPORATION AHMEDABAD-380008,INDIA	CLIENT:																	
3.							Client's Ref. No																	
2.							Model Code- FLPV-1112																	
1.							Drg No: FLPV-1112-CS																	
NO.	DATE	MATTER	BY.				File Location D:\ Products\Valves-FLPV-1112																	
REVISION STATUS						TITLE: ANCHOR FLAP VALVE SQUARE BODY FLANGE END- MANUAL																		
<table border="1"> <tr> <td>DRN</td> <td>AMP</td> <td>28-11-10</td> </tr> <tr> <td>DGN</td> <td>PMM</td> <td>28-11-10</td> </tr> <tr> <td>CHD</td> <td>PMM</td> <td>28-11-10</td> </tr> <tr> <td>APPR</td> <td></td> <td></td> </tr> <tr> <td>SCALE</td> <td>N.T.S.</td> <td></td> </tr> </table>						DRN	AMP	28-11-10	DGN	PMM	28-11-10	CHD	PMM	28-11-10	APPR			SCALE	N.T.S.		Doc.No. Doc.No.		CLIENT: Client's Ref. No	
DRN	AMP	28-11-10																						
DGN	PMM	28-11-10																						
CHD	PMM	28-11-10																						
APPR																								
SCALE	N.T.S.																							